





# INDEX

<b>ABOUT US</b>	<b>2</b>
<b>CRUCIBLES</b>	<b>5</b>
<b>ACCESSORIES FOR FUSION MACHINES</b>	<b>13</b>
<b>SERVICES AND ACCESSORIES</b>	<b>23</b>
<b>SPUTTERING TARGETS</b>	<b>27</b>
<b>BENCHTOP XRF ANALYZERS</b>	<b>31</b>
<b>PORTABLE XRF ANALYZERS</b>	<b>39</b>
<b>ELECTRIC FUSION MACHINES</b>	<b>47</b>
<b>PLATINUM CARE</b>	<b>59</b>

# ABOUT US



8853 S.p.A. is a historic Italian company and a leader in the precious metals industry. Established more than 60 years ago as Mario Villa Banco Metalli, 8853 S.p.A. was born thanks to the ideas and skills of Mario Villa, the company's founder, and later of his son Giorgio Villa, the current CEO. 8853 S.p.A. is a versatile and constantly evolving company, which is the key to its success and continued relevance in the sector. Its expertise has led to the creation of four distinct Business Units: **OROVilla**, dedicated to investment gold, **Banco Villa**, specializing in the production of semi-finished products, **88Labware**, focused on the production of platinum crucibles and distribution of electric pearling machines, and **88dent**, engaged in the production and marketing of innovative solutions in the dental field.

## 4 Business Units





# TRUST IN 88LABWARE



## UNBEATABLE PRICES

Discover how much you can save: we are manufacturers.



## FAST DELIVERY

Receive your items in no time, cutting-edge technology & experience.



## CUSTOM DESIGNS

Can't find what you need? Let's create it together. Free consultation.



## VAST SELECTION

Explore our wide range of solutions for all your needs.



## PERSONALIZE YOUR ITEMS

Add a unique touch with your own engraving



# 88LABWARE: EXPERIENCE YOU CAN TRUST



## TRANSPORT INSURED

To ensure your peace of mind, 88Labware provides insured shipping service: safe shipping.

**We will take care of organizing everything and all you have to do is wait for the delivery of your product with peace of mind.**



## PLATINUM RECOVERY

Reduce waste, conserve resources. Choose 88Labware for sustainable precious metal recovery.

The process includes: safe collection of spent items, merging and analysis. The recovered precious metals are then reused for new production.

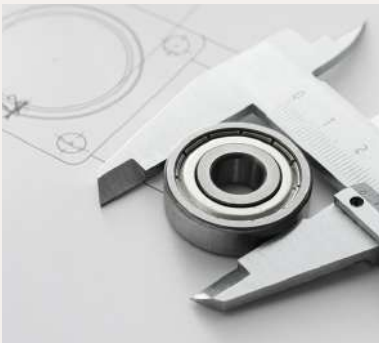

## DESIGN AND DEVELOPMENT

Leveraging decades of experience since the 1960s, 88Labware goes beyond offering catalog products. We are specialized in customized solutions, developing new items tailored to your specific needs.



# CRUCIBLES

PRODUCTION AND DEVELOPMENT  
MADE IN ITALY



All 88Labware products can be supplied in different alloys: platinum, platinum-iridium, platinum-gold, platinum-gold-rhodium, platinum-rhodium, platinum-high temperature and other precious alloys also upon customer request.

## Standard crucibles



Code	Ø top. (mm)	Ø bott. (mm)	Height (mm)	Weight (g)	Thickness (mm)	Capacity (ml)
A00	25,0	13,0	31,0	10,0	0,23	10
A01	29,5	15,9	32,5	12,0	0,23	15
A02	30,0	17,5	31,5	20,0	0,28	15
A03	32,5	16,5	35,5	18,0	0,29	20
A04	35,0	23,0	40,0	30,0	0,39	25
A05	35,0	20,0	38,0	18,0	0,25	25
A06	36,0	24,0	40,0	27,0	0,33	25
A07	37,5	23,0	41,5	23,0	0,28	30
A09	39,0	26,5	43,0	28,0	0,27	35
A10	40,0	24,0	43,0	29,0	0,27	35
A11	41,5	24,9	45,5	31,0	0,30	40
A13	44,0	25,0	48,5	42,0	0,37	50
A14	47,0	29,0	46,0	45,0	0,38	55
A15	50,0	31,0	55,0	55,0	0,42	75
A16	63,0	40	59	63	0,26	100
A17	56,0	32,0	62,0	78,0	0,49	100
A51	110,0	75	120,0	400	0,40	600

## Conical crucibles



Code	Ø top. (mm)	Ø bott. (mm)	Height (mm)	Weight (g)	Thickness (mm)	Capacity (ml)
C01	26,0	16,0	28,0	9,0	0,25	10
C02	28,0	20,0	32,0	12,0	0,36	15
C03	29,0	18,0	32,0	12,0	0,29	15
C04	30,0	27,0	35,0	13,0	0,19	20
C05	32,0	19,0	35,0	14,0	0,23	20
C06	35,0	30,0	40,0	29,0	0,36	30
C07	35,0	22,0	39,0	17,0	0,22	25
C08	35,0	25,0	40,0	32,0	0,40	30
C09	38,0	23,0	41,0	20,0	0,21	30
C10	38,0	27,0	38,0	22,0	0,26	32
C11	40,0	22,0	40,0	24,0	0,28	35
C12	43,0	28,0	30,5	27,0	0,27	35
C13	42,0	29,0	39,0	30,0	0,24	40
C14	43,0	29,0	37,0	35,0	0,22	45
C15	48,0	35,0	48,0	43,0	0,31	50
C16	45,5	29,0	50,0	45,0	0,33	50
C17	50,0	30,0	55,0	42,0	0,25	60
C19	55,0	32,0	50,0	60,0	0,43	65
C20	60,0	38,0	60,0	200	1,00	100
C21	70,0	50,0	30,0	35,0	0,21	70
C22	95,0	65,0	100	162	0,30	475
C23	110	100	100	500	350	500

## Cylindrical crucibles



Code	Ø top. (mm)	Height (mm)	Weight (g)	Thickness (mm)	Capacity (ml)
B01	30,0	50,0	165	1,50	35
B02	34,0	50,0	31,0	0,25	35
B03	40,0	75,0	315,0	1,40	90
B04	43,5	50,0	44,0	0,25	60
B05	45,0	70,0	370,0	1,40	100
B06	70,0	90,0	997,0	2,00	340
B07	50,0	50,0	100,0	0,45	75

## Low crucibles



Code	Ø top. (mm)	Ø bott (mm)	Height (mm)	Weight (g)	Thickness (mm)	Capacity (ml)
D03	32,0	18	26,5	13,0	0,28	15
D05	38,0	22	41,0	24,0	0,30	30
D06	40,0	24	34,0	21,0	0,26	40
D07	43,5	26	36,0	26,0	0,33	35
D08	46,0	28	37,0	32,0	0,38	40

## Standard capsules



Code	Ø top. (mm)	Height (mm)	Weight (g)	Thickness (mm)	Capacity (ml)
F01	38,0	19	10,0	0,21	15
F02	40,0	20	11,5	0,20	20
F03	42,0	20	12,5	0,20	20
F05	50,0	22	15,5	0,18	30
F07	55,0	22	18,0	0,19	35
F09	60,0	22	19,0	0,17	40
F11	62,5	27	23,5	0,18	60
F13	70,0	28	28,0	0,18	80
F15	75,0	29	32,5	0,20	100
F16	80,0	31	39,0	0,22	125
F19	82,5	31	45,0	0,20	150
F21	90,0	38	62,0	0,25	175
F23	100,0	35	75,0	0,25	200
F24	115,0	30	100,0	0,25	220
F25	130,0	25	224	0,44	240

## Cylindrical capsules



Code	Ø top. (mm)	Height (mm)	Weight (g)	Thickness (mm)	Capacity (ml)
B08	60,0	35,0	68,0	0,42	120
B11	70,0	20,0	30,0	0,35	75
B12	75,0	50,0	50,0	0,24	150
B13	80,0	25,0	68,0	0,30	120
B14	85,0	40,0	75,0	0,28	150
B15	90,0	30,0	75,0	0,28	130

## Conical capsules



Code	Ø top. (mm)	Ø bott. (mm)	Height (mm)	Weight (g)	Thickness (mm)	Capacity (ml)
G01	50,00	40,00	30,00	28,00	0,32	30
G02	50,00	32,00	35,00	30,00	0,32	40
G03	66,0	40,00	35,00	31,00	0,28	60
G05	70,00	45,00	35,00	35,00	0,22	75
G07	75,00	50,00	38,00	38,00	0,15	100
G09	80,00	55,00	35,00	62,00	0,18	105
G11	85,00	60,00	38,00	46,00	0,18	125
G13	90,00	70,00	35,00	51,00	0,20	145
G16	100,00	75,00	30,00	41,00	0,16	140

## Low hemispherical bottom capsules



Code	Ø top. (mm)	Height (mm)	Weight (g)	Thickness (mm)	Capacity (ml)
J04	55,00	22,00	18,00	0,18	30,00
J06	63,00	27,00	24,00	0,18	60,00
J08	75,00	29,00	37,00	0,22	100,00

## Lids



Code	Ø (mm)	Weight (g)	Thickness (mm)	Code	Ø (mm)	Weight (g)	Thickness (mm)
M00	25,00	3,50	0,18	M14	45,0	8,00	0,20
M01	26,00	3,50	0,18	M15	50,00	10,00	0,20
M02	30,00	5,00	0,18	M17	55,00	18,00	0,19
M03	32,00	6,00	0,18	M19	58,00	20,00	0,20
M05	34,0	6,00	0,18	M20	62,00	22,00	0,20
M07	37,00	6,00	0,19	M21	64,00	22,00	0,20
M09	39,0	8,00	0,20	M23	69,0	25,00	0,23
M11	40,5	8,00	0,20	M25	75,00	26,00	0,20
M13	44,0	8,00	0,20	M26	80,00	28,00	0,20

## Boats



Code	Length (mm)	Width (mm)	Height (mm)	Weight (g)	Thickness (mm)	Grip (mm)
N03	20,00	4,00	3,00	2,50	0,60	5,00
N04	30,00	9,50	6,00	6,00	0,22	5,00
N07	58,00	9,50	8,00	8,00	0,22	10,00
N10	100,00	25,00	10,00	80,00	1,40	10,00



# ACCESSORIES FOR FUSION MACHINES



## Crucibles for Katanax fusion machines

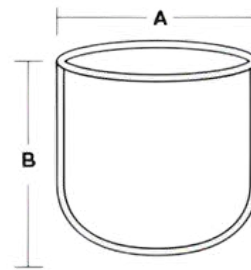

Code	A (mm)	B (mm)	Rim	Thickness (mm)	Weight (g)
KT1	40,0	31,5	Straight	0,30	26,0
KT2	40,0	31,5	Straight	0,43	37,0
KT3	40,0	32,0	Flared	0,40	37,0
KT4	40,0	32,0	Flared	0,30	28,0
KT7	40,0	32,0	Reinforced	0,30	30,0

## Crucibles for Neika fusion machines

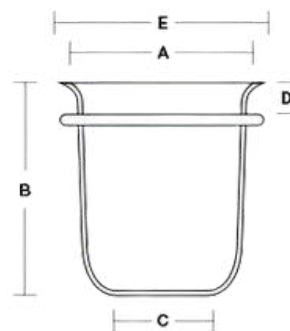

Code	A (mm)	B (mm)	C (mm)	D (mm)	E (mm)	Weight (g)
NK1	40,0	32,0	20,0	5,0	42,0	31,0

## Crucibles for Equilab fusion machines

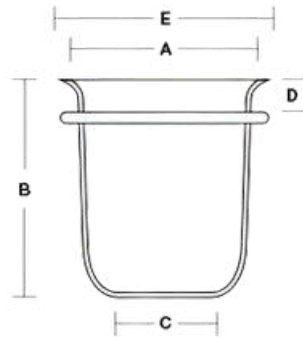

Code	A (mm)	B (mm)	C (mm)	D (mm)	E (mm)	Weight (g)
EQ1	36,0	28,0	34,0	5,0	37,0	55,0
EQ2	36,0	28,0	34,0	5,0	37,0	50,0

## Crucibles for Claisse fusion machines

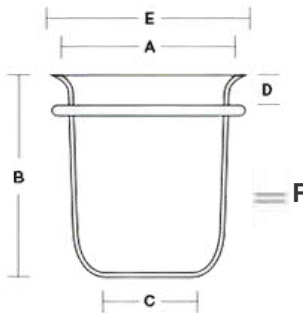

Code	A (mm)	B (mm)	C (mm)	D (mm)	E (mm)	F (mm)	Weight (g)
CL8	39,0	32,0	20,0	5,0	41,0	0,70	49,5
CL8A	39,0	32,0	20,0	5,0	41,0	0,44	31,0

## Crucibles for Herzog fusion machines

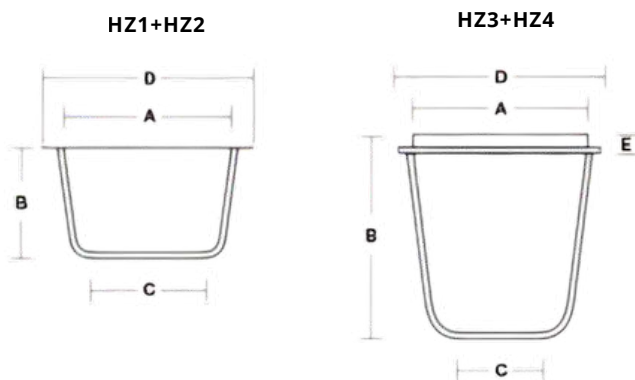

Code	A (mm)	B (mm)	C (mm)	D (mm)	E (mm)	Weight (g)
HZ1	49,0	30,0	37,0	-	-	90,0
HZ2	49,0	30,0	40,0	56,0	-	110,0
HZ3	38,0	36,0	24,0	44,0	12,8	44,0
HZ4	38,0	39,0	24,0	44,0	12,8	52,0

## Crucibles for Panalytical fusion machines - EAGON 2

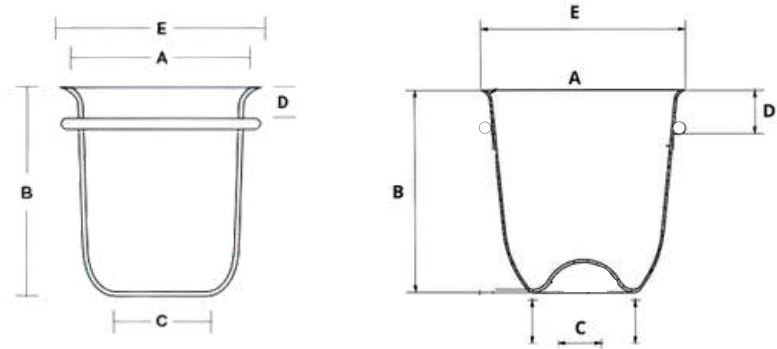

Code	A (mm)	B (mm)	C (mm)	D (mm)	E (mm)	Weight (g)	Version
CL7	37,5	37,0	18,7	8,0	40,0	40,3	Bottom with dimple
CL7A	37,5	37,0	18,7	8,0	40,0	40,0	Flat bottom

## Crucibles for Perl'X fusion machines

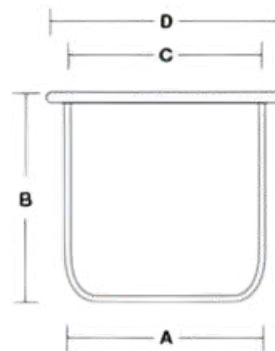

Code	A (mm)	B (mm)	C (mm)	D (mm)	Weight (g)
PX1	41,0	40,0	41,0	49,0	116,0
PX2	41,0	40,0	41,0	49,0	80,0
PX3	44,0	40,0	44,0	52,0	90,0
PX4	38,0	40,0	42,0	50,0	75,0

## Crucibles for Vulcan fusion machines

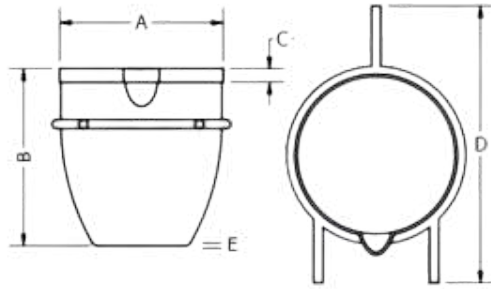

Code	A (mm)	B (mm)	C (mm)	D (mm)	E (mm)	Weight (g)
VLC5	34,0	38,0	12,0	60,0	0,35	25,0
VLC6	34,0	38,0	12,0	60,0	0,5	44,0
VLC9	34,0	38,0	12,0	60,0	0,34	34,0
VLC7	36,0	38,0	12,0	60,0	0,5	51,0
VLC8	34,0	38,0	12,0	NA	0,5	44,0

## Crucibles for Vitriox fusion machines

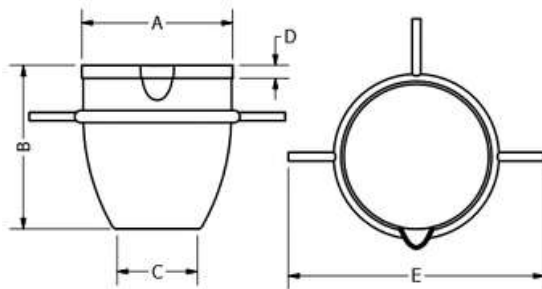

Code	A (mm)	B (mm)	C (mm)	D (mm)	E (mm)	Weight (g)
VX1	39	36	20	3	60	54,0

## Crucibles for xrFuse fusion machines

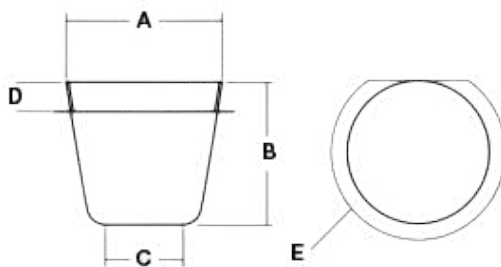

Code	A (mm)	B (mm)	C (mm)	D (mm)	E (mm)	Weight (g)
XF1	36,0	38,0	19,0	6,0	0,44	30,0
XF2	36,0	38,0	19,0	6,0	0,55	40,0

## Molds for Katanax fusion machines

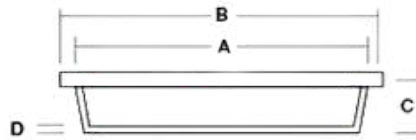

Code	A (mm)	B (mm)	C (mm)	D (mm)	Weight (g)
KTM1	32/30	39,0	6,0	0,8	21,0
KTM2	32/30	39,0	6,0	1,0	27,0
KTM3	34/32	41,0	6,0	0,8	23,0
KTM4	34/32	41,0	6,0	1,0	29,0
KTM5	37/35	44,0	6,0	1,2	36,0
KTM6	37/35	44,0	6,0	0,8	26,0
KTM7	37/35	44,0	6,0	1,0	33,0
KTM8	37/35	44,0	6,0	1,2	40,0
KTM9	40/38	48,0	6,0	0,8	34,0
KTM10	40/38	48,0	6,0	1,0	43,0
KTM11	42/40	49,0	6,0	0,8	35,0
KTM13	42/40	49,0	6,0	1,1	48,0
KTM14	41.5/39.5	49,0	4,0	0,8	37,5

## Molds for Neika fusion machines

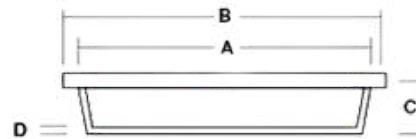

Code	A (mm)	B (mm)	C (mm)	D (mm)	Weight (g)
NKM1	32/30	49,0	6,0	1,0	30,0
NKM2	34/32	49,0	6,0	1,0	30,0
NKM3	38/36	49,0	6,0	1,0	32,0
NKM4	42/40	49,0	6,0	1,0	32,0

## Molds for Equilab fusion machines

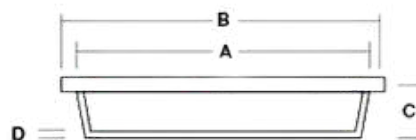

Code	A (mm)	B (mm)	C (mm)	D (mm)	Weight (g)
EQM1	31/29	49,0	5,5	0,8/1,0	40,0
EQM2	33/31	49,0	5,5	0,8/1,0	40,0
EQM3	36/35	49,0	5,5	0,8/1,0	40,0
EQM4	41/39	49,0	5,5	0,8/1,0	40,0

## Molds for Claisse fusion machines

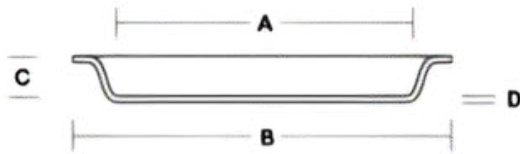

Code	A (mm)	B (mm)	C (mm)	D (mm)	Weight (g)
CLM1	32/30	39,0	6,0	0,8	21,0
CLM2	32/30	39,0	6,0	1,0	27,0
CLM3	34/32	41,0	6,0	0,8	28,0
CLM4	34/32	41,0	6,0	1,0	36,0
CLM5	37/35	44,0	6,0	0,8	30,0
CLM6	37/35	44,0	6,0	1,0	37,5
CLM8	40/38	48,0	6,0	0,8	35,0
CLM9	40/38	48,0	6,0	1,0	43,0
CLM10	42/40	49,0	6,0	0,8	40,0
CLM11	42/40	49,0	6,0	1,0	48,0

## Molds for Herzog fusion machines

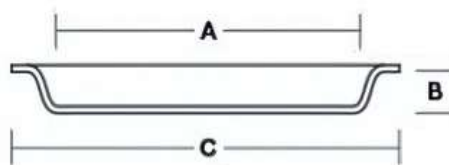

Code	A (mm)	B (mm)	C (mm)	Weight (g)
HZM1	29/31	3,0	44,0	40,0
HZM2	38/41	3,0	52,0	50,0
HZM3	39/41	4,0	50,0	30÷100
HZM4	39/41	4,0	50,0	120,0
HZM5	32/34	3,5	44,0	60,0

## Molds for Panalytical fusion machines - EAGON 2

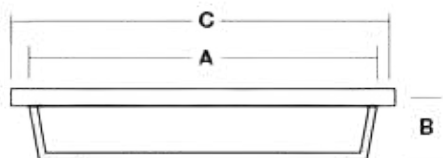

Code	A (mm)	B (mm)	C (mm)	Weight (g)
PNM1	32,5/31	4,5	50,0	40,0÷60,0
PNM3	40,5/39	4,5	56,0	58,0÷69,0

## Molds for Perl'X fusion machines

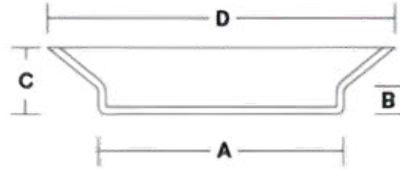

Code	A (mm)	B (mm)	C (mm)	D (mm)	Weight (g)
PXM2	30/32	3,0	5,0	55,0	40,0
PXM3	30/32	3,5	11,5	65,0	50,0
PXM8	32/34	3,5	11,5	65,0	50,0
PXM10	34/36	3,0	5,0	55,0	50,0

## Molds for Vulcan & Vitriox (square shape)

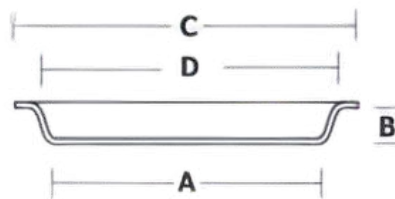

Code	A (mm)	B (mm)	C (mm)	D (mm)	Weight (g)
VCM3	34,0	3,0	41,0	32,0	31,0
VCM5	36,0	3,0	51,0	34,0	45,0
VCM7	41,0	3,0	51,0	39,0	46,0
VCM8	41,0	3,0	51,0	39,0	57,0

## Molds for xrFuse beading machines

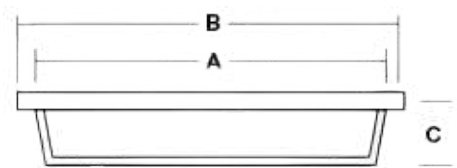

Code	A (mm)	B (mm)	C (mm)	Weight (g)
AM1	31/29	42,0	3,0	<59,0
AM1	31/29	42,0	3,0	>60,0
AM2	32/30	42,0	3,0	<59,0
AM2	32/30	42,0	3,0	>60,0
AM3	32/30	42,0	4,0	<59,0
AM3	32/30	42,0	4,0	>60,0
AM4	32/30	46,0	3,0	<59,0
AM4	32/30	46,0	3,0	>60,0
AM5	34/32	46,0	3,0	<59,0
AM5	34/32	46,0	3,0	>60,0
AM6	35/33	46,0	3,0	<59,0
AM6	35/33	46,0	3,0	>60,0
AM6.4	35/33	46,0	4,0	<59,0
AM6.6	35/33	46,0	4,0	>60,0
AM12	35/33	55,0	3,0	<59,0
AM12	36/34	55,0	3,0	>60,0
AM13	40/38	52,0	4,0	<59,0
AM13	40/38	52,0	4,0	>60,0
AM7	41/39	52,0	3,0	<59,0
AM7	41/39	52,0	3,0	>60,0
AM7.5	41/39	52,0	5,0	<59,0
AM7.5	41/39	52,0	5,0	>60,0
AM8	41/39	56,0	3,0	<59,0
AM8	41/39	56,0	3,0	>60,0

## Square Molds



Code	Edge length (mm)	∅ top / bott. (mm)	Height (mm)	Thickness (mm)	Weight (g)
L51	41,0	31/29	3,0	0,80	30,0
L52	41,0	34/32	3,0	0,80	31,0
L55	51,0	38/34	3,0	1,00	45,0
L57	51,0	41/39	3,5	1,10	65,0

## Round Molds



Code	Edge width (mm)	∅ top / bott (mm)	Height (mm)	Thickness (mm)	Weight (g)
L01	42,0	32/30	4,0	1,35	40,0
L02	50,0	33,5/ 30,5	45,0	1,2	50,0
L03	44,0	36/35	8,0	0,8	32,0
L04	44,0	36/34	6,0	1,0	42,0
L05	48,5	41,5/39,5	7,0	1,0	49,0
L06	50,0	40,5/39,5	5,5	0,65	30,0
L07	50,0	41/41	11,0	0,6	32,0
L08	55,0	31/30	3,5	1,0	52,0
L09	60,0	43/40	3,5	1,0	60,0
L10	60,0	40,5/39,5	3,5	1,5	102,0
L11	65,0	40,5/39,5	3,5	0,8	56,0
L13	65,0	31,5/30	10,4	1,0	56,0
L15	65,0	32/30,5	3,5	1,0	53,0
L16	65,0	36/34	3,5	1,0	60,0
L17	65,0	34/32	3,5	1,0	80,0
L20	50,0	34/32	3,0	1,0	45,0

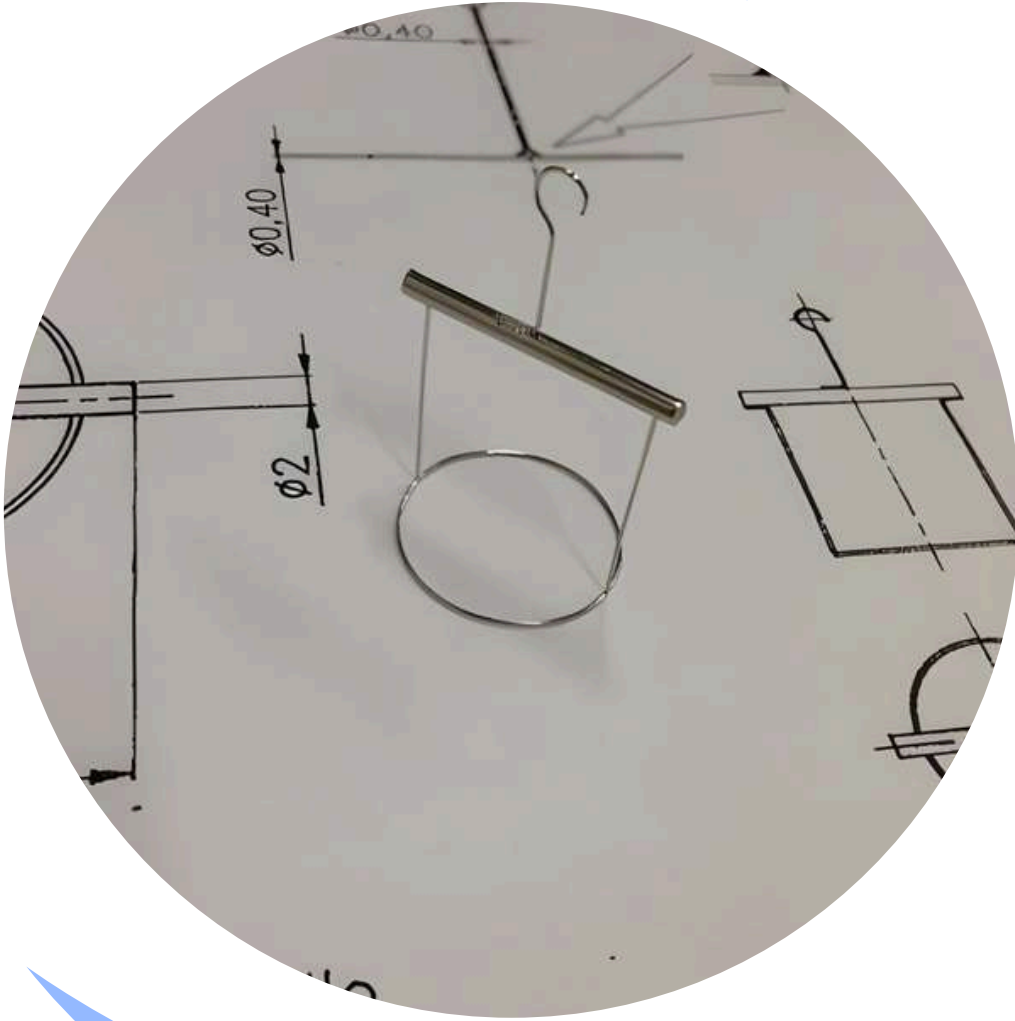

# SERVICES AND ACCESSORIES



Service



Refinement



Maximize savings with our crucible recovery and remanufacturing service: Recover precious metals from used crucibles and reuse them for new ones, saving money and resources.

**Easy process:** we arrange safe pickup of your crucibles.

**Expert recovery:** our team extracts precious metals using advanced techniques.

**See-through process:** we track the metal contained in your dedicated account and adjust any differences at the end of the operation.

**Convenient service:** fast door-to-door pickup and delivery



**88labware offers a wide range of complementary accessories to support the activities of the analytical laboratory, which can also be produced upon customer request.**

88Labware Platinum cleaning kit: restores the luster of your platinum material quickly and easily.

Everything you need for perfect cleaning:

- Portable milling machine (from 10,000 to 30,000 rpm) 220 V electric operation;
- Mixed bit kit (cutting, polishing, sanding, drilling);
- Abrasive for removing large impurities and scratches;
- Diamond paste for polishing;
- Polishing cloth;
- Mirror finish cloth;
- Manual



CRUCIBLE  
TONGS WITH  
PLATINUM TIP  
COATING

**The pliers are made of stainless steel with platinum-coated tips: theoretical weight of 8 g**

	Length	Weights (g)
<b>Plier 200</b>	<b>200 mm</b>	<b>8</b>
<b>Plier 300</b>	<b>300 mm</b>	<b>8</b>
<b>Plier 500</b>	<b>500 mm</b>	<b>8</b>

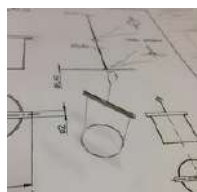

DE NOUY  
RINGS AND  
WILHELMY  
PLATES

**De Nouy rings and Wilhelmy plates are instruments used to measure the surface tension of a liquid. Surface tension is the force along the surface of a liquid, trying to minimize its area.**

De Nouy rings consist of a thin ring immersed in liquid, while Wilhelmy plates consist of a solid plate or filament immersed in liquid, and surface tension affects the height of the liquid on the object.

Shapes and dimensions upon customer request

- **Mixers and Spatulas with or without handle**
- **Loops, Needles, Eyelets in platinum for microbial applications**

All 88Labware products can be supplied in platinum, platinum-iridium, platinum-gold, platinum-gold-rhodium, platinum-rhodium, platinum-high temperature and other precious alloys also upon request.

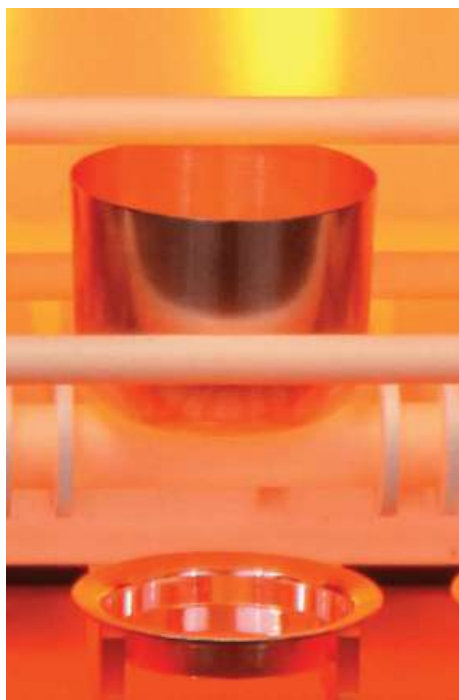

**88**  
*Labware*  
Your Lab Platinum Partner





# SPUTTERING TARGETS



## Au 99.99%

Code	Diameter	Weight (g)	Thickness (mm)	
SP-AU25,4X1	25,4	9,77	1	
SP-AU50,8X0,1	50,8	3,91	0,1	
SP-AU50,8X0,2		7,82	0,2	
SP-AU50,8X0,5		19,55	0,5	
SP-AU50,8X1		39,10	1	
SP-AU50,8X1,6		62,56	1,6	
SP-AU50,8X1.5		58,70	1,5	
SP-AU50,8X2		78,20	2	
SP-AU50,8X3		117,29	3	
SP-AU50,8X3,17		123,94	3,17	
SP-AU50,8X4		156,39	4	
SP-AU50,8X5		195,49	5	
SP-AU50,8X6		234,59	6	
SP-AU50,8X6,35		248,30	6,35	
SP-AU50X0,1		50	3,90	0,1
SP-AU50X1		37,88	1	
SP-AU54X0.1	54	4,42	0,1	
SP-AU57X0.1	57	4,92	0,1	
SP-AU57X0.2		9,84	0,2	
SP-AU57X0.3		14,77	0,3	
SP-AU57X0.4		19,69	0,4	
SP-AU57X0.5		19,69	0,4	
SP-AU57X1		49,27	1	
SP-AU60X0.1	60	5,50	0,1	
SP-AU62X0.1	62	5,82	0,1	
SP-AU63X0.1	63	6,01	0,1	
SP-AU64X0.1	64	6,21	0,1	
SP-AU65X0.1	65	6,40	0,1	
SP-AU73X0.1	73	8,00	0,1	
SP-AU75X0.1	75	8,52	0,1	
SP-AU76,2X1	76,2	87,97	1	
SP-AU76,2X2		175,94	2	
SP-AU76,2X3		263,91	3	
SP-AU76,2X3,17		278,87	3,17	
SP-AU76,2X6,35		558,61	6,35	
SP-AU101.6X2	101,6	313	2	
SP-AU203,2X2	203,2	1.252	2	

## AU6PD4 Au 60% Pd 40%

Product	Diameter	Weight (g)	Thickness (mm)
SP-AU6PD450X0.1	50	3,50	0,1
SP-AU6PD457X0.1	57	4,18	
SP-AU6PD460X0.1	60	4,64	
SP-AU6PD462X0.1	62	5,00	
SP-AU6PD473X0.1	73	6,86	

## AU8PD2 Au 80% Pd 20%

Product	Diameter	Weight (g)	Thickness (mm)
SP-AU8PD254X0.1	54	4,00	0,1
SP-AU8PD257X0.1	57	5,20	
SP-AU8PD258X0.1	58	5,40	
SP-AU8PD260X0.1	60	4,80	

## Ag 99.99%

Product	Diameter	Weight (g)	Thickness (mm)
SP-AG54X0.1	54	2,40	0,1
SP-AG54X0.1-9999		2,40	0,1
SP-AG54X0.2-9999		4,81	0,2
SP-AG57X0.1	57	2,68	0,1
SP-AG57X0.1-9999		2,68	0,1

## Pd 99,95%

Product	Diameter	Weight (g)	Thickness (mm)
SP-PD57X0.1	57	3,07	0,1
SP-PD60X0.1	60	3,40	0,1
SP-PD73X0.1	73	5,03	0,1

## Pt 99,99%

Product	Diameter	Weight (g)	Thickness (mm)
SP-PT50,8X0,1	50,8	4,35	0,1
SP-PT57X0.1-9999	57	5,47	0,1
SP-PT8PD257X0.1	57	5,00	0,1
SP-PT9999-57X0.1		5,50	0,1

## Pt 99.95%

Product	Diameter	Weight (g)	Thickness (mm)
SP-PT20X1	20	7,00	1
SP-PT33X1	33	18,34	1
SP-PT54X0.1	54	4,91	0,1
SP-PT60X0.1	60	6,06	0,1
SP-PT63X0.1	63	6,68	0,1
SP-PT73X0.1	73	8,97	0,1
SP-PT101.6X0,2	101,6	35,00	0,2



# BENCHTOP XRF ANALYZERS





## GOLD SCAN PRO

The Gold Scan Pro is designed to deliver fast, reliable analysis of catalysts, alloys, minerals, plastics, and soils, providing clear results without the need for complex sample preparation.

Its customizable element configuration allows the system to adapt to each customer's specific requirements. With instant response times and an intuitive interface, the instrument supplies actionable data within seconds, enhancing operational efficiency and improving the accuracy of verification processes.



Includes a Bluetooth printer



Equipped with camera for analysis point detection

## GOLD SCAN PRO S

The Gold Scan Pro S delivers higher sensitivity than the standard model, ensuring more precise analysis across demanding applications. Its customizable element configuration allows the system to adapt to each customer's specific analytical needs. Thanks to its enhanced sensitivity and improved operational stability, the Gold Scan Pro S provides immediate results in the laboratory, ensuring efficiency and continuity even in the most intensive work environments.



Includes a Bluetooth printer



Equipped with camera for analysis point detection



## Technical characteristics of Gold Scan Pro

<b>Weight</b>	34.5kg
<b>Size of Host Machine</b>	362mm×530mm×343mm (W×D×H)
<b>Sample Chamber Size</b>	262mm×297mm×110mm (W×D×H)
<b>Display screen</b>	11.6-inch large capacitive touchscreen
<b>Detection range</b>	Al—U
<b>Tube window</b>	Glass
<b>Optical structure</b>	Vertical optical path
<b>Detector</b>	Si-Pin/SDD (Optional)
<b>Collimator</b>	<b>Gold Scan Pro PS6:</b> 2.5mm collimator <b>Gold Scan Pro PS7:</b> 1.5mm collimator
<b>Camera</b>	The built-in 5 megapixel HD CMOS color camera can not only provide users with intuitive sample positioning and image recording function, but also ensure that the X-ray accurately illuminate to the target area, improving the operation accuracy.
<b>Power supply</b>	Supports 100-240VAC, 50/60Hz
<b>One-click test button</b>	Place the sample- -close the top cover- one-click test- view the results' operation is simple for non-technical personnel to analyze by themselves
<b>Algorithm</b>	Adopts curve calibration method and fundamental parameter(FP) method to remove background difference, reduce error and improve test accuracy.
<b>Data printing</b>	Bluetooth printer

### Calibration:

ingots, yellow gold, rose gold, white gold, platinum, silver, powders

### Analyzable elements:

Au, Ag, Pd, Pt, Rh, Ru, Ir, W, Fe, Cr, Co, Ni, Cu, Ti, Zn, Se, Cd, In, Pb

## Advantages of Gold Scan Pro

### NDT

No need to process samples in the early stage, realizing nondestructive test of precious metals simply, conveniently and fast.

### ONE-CLICK INTELLIGENT OPERATION

The entire analysis process can be done in several seconds. The operation is simple and can be easily mastered by non-technical personnel.

### HIGH ACCURACY

XRF technology provides reliable purity and composition data with an accuracy up to 0.01%.

### PERFECT SAFETY PROTECTION

Various safety protection mechanism including high voltage safety lock (automatic interlock), software opening cover, anti-leakage protection switch and all-metal closed shell fundamentally ensure the personal safety of operators and avoid radiation caused by accidental operation.

### SAMPLE FLEXIBILITY

Various forms of samples, as well as small parts on samples such as joints, buttons, inlays and gem support can be easily tested.

### INTEGRATED DESIGN

The precious metal XRF analyzer adopts an integrated design, takes up very little space, and is suitable for various counters, testing institutions, laboratories and other scenarios.



## 88 SCOPE



### Fields of application

- Minerals & Mining (980)
- Coal ash, catalysts (980)
- Cement and building materials (980)
- Metallic alloys (860)
- Ceramics, glass and industrial materials (980)

The **88 SCOPE** XRF analyzer features highly innovative software and high-quality hardware, featuring a wide linear range, fast analysis, good reproducibility and high accuracy. Sample preparation is simple, sample size and shape can be different (powders, tablets, beads), and high sample handling capacity can be realized. Suitable for large-scale continuous analysis, process control, product quality inspection, it is an ideal tool for coatings, precious metals, cement, minerals, alloys, plastics and other industries.

### Advantage

- High performance configuration
- The combination of low energy X-rays with the vacuum system allows the identification and analytical precision of elements such as Si, P, S, Al, Mg even in the presence of high concentrations of iron and chromium.

### Wide variety of collimators and filters.

Four types of collimators: 5 mm, 3 mm, 1 mm, 0.5 mm. Collimators and filters can be automatically switched via software, saving time and effort. Through the appropriate combination of collimators and filters it is possible to improve the precision and sensitivity of the instrument.

### Non-destructive checks

XRF analysis, called NDT (non-destructive) analysis, does not damage or influence the performance of the tested object.

### Peltier refrigeration

Cooling with Peltier system: reduces the complexity of the device and saves on maintenance costs.

### Data transmission

USB, WIFI, Bluetooth.

### Customization

The analysis report can be exported to EXCEL or PDF. Users can customize the test report, including company logo, spectrum and other sample information.

### Safety

Metal frame, safety switch and door with automatic opening and closing.

## Technical characteristics of 88 SCOPE analyzers

<b>Weight</b>	55 kg
<b>Dimension</b>	570×400×400mm (D x W x H)
<b>Tube</b>	W/Ag/Au/Rh)
<b>Detector</b>	SDD detector
<b>Technique</b>	XRF EDX with vacuum pump
<b>Characteristics</b>	Voltage 5-50KV, Current 0-1000 μA, Power 50W
<b>Analytical Range</b>	11Na - 92U
<b>Resolution</b>	< 125 eV
<b>Sample status</b>	Solid, liquid, powder
<b>Cooling down</b>	By air-peltier
<b>Camera</b>	HD 5 megapixel, industrial
<b>Operating system</b>	PC Windows latest stable version, 500Gb, HDD, 4G RAM or expandable

## Application Fields



Cement, limestone



Coal power



Petrochemical



Ore exploration and development, rock, rare earth element analysis



Coal mining, coal washing and coal blending



Iron and steel melting

## 88 OIL ADVANCE



- Simultaneous analysis of Sulfur and Chlorine in petroleum products
- Compact and portable
- Works in vacuum with integrated mini pump
- Meets the requirements of ASTM standards: 4294, D6445, 7220, 4929. Meets the requirements of ISO standards: 8754, 20847
- Meets the requirements of IP standards: 336, 496

The analytical range of the 88 OIL ADVANCE instrument goes from a concentration of 4 ppm to 10%: it is equipped with an SDD detector with Peltier cooling, spectral resolution <math><130\text{eV}</math> (Mn K $\alpha$ )

### Technical specifications

Detector	Fast high resolution SDD
Source of excitement	4 W, 50kv Max, 200uA Max
Working temperature	yes -20 to 50 °C
Analyses	88 OIL Advance in vacuum, 88 OIL in air
Analysis Time	120-300 seconds, customizable
Sample type	Liquid, powder, solid
Cups	ID-23.6mm, OD-30mm, Altezza 30mm, Volume-9ml
Dimensions of the instrument	270mmx320mmx230mm (D x W x H)
Sample chamber dimensions	170mmx110mmx17mm (D x W x H)
Weight	10.5 kg for 88 OIL Advance, 9.4 kg for 88 OIL
Touch screen(1280*800)	8 pollici Windows 10 based OS
External peripherals	USB, Bluetooth, Wi-Fi, GPS
Test Report	Excel, PDF
Consumables	Sample mylar - cups - pipette - vacuum film
<b>88 OIL Advance</b>	
<b>Typical calibration</b>	Sulfur high concentrations: 0.01%-5% 1ppm at 300seconds
LOD S	1ppm at 300 seconds
LOD Cl	1ppm at 300 seconds
<b>88 OIL</b>	
<b>Typical calibration</b>	Sulfur low concentrations: 20ppm- 100ppm S ulfur high concentrations: 0.01%-5%
LOD S	3.8 ppm at 130 seconds



# PORTABLE XRF ANALYZERS





## WALLY ADVANCE

Small, light, fast and easy to use.

High performance due to high spectral resolution

Industrial touch display, automatic brightness adjustment.

Real-time battery management or direct mains power supply.

Humidity and temperature parameters monitored in order to keep within environmental specifications.

Customizable work reports: logo, address, description, source and batch can be added.

Before each analysis, the instrument always checks that the analysis door is closed.

The instrument can be configured and verified via the web.



Includes a Bluetooth printer



Equipped with camera for analysis point detection

## WALLY ADVANCE S

Wally Advance S is a compact, safe and high quality XRF (EDXRF) instrument.

The particular design of the Gold Advance S, powered by electricity or battery, makes it bivalent: both portable and benchtop, one of a kind.

With autonomous computational capabilities, the Gold Advance S is independent and can be used in different scenarios: gold buyers, metal banks, jewelers, gold industries, foundries, museums, coin collectors, etc. The optional camera allows you to precisely locate, focus and analyze the sample point or points.

The SDD version has higher analytical accuracy than the Si Pin version.



Includes a Bluetooth printer



Equipped with camera for analysis point detection



## Wally technical characteristics

<b>Dimensions</b>	200 (W) x 200 (D) x 268 (H) mm
<b>Analytical area dimensions</b>	170 (W) x 130 (D) x 60 (H) mm
<b>Weight</b>	3Kg
<b>Source</b>	Ag (standard), Au, W, Rh (optional)
<b>Power of the source</b>	40KV/200µA, 4W
<b>Detector</b>	Si-PIN/SDD
<b>PC</b>	i.mx6 Quad core Cortex-Ag processor Operating system dedicated to metal identification, 32GB memory
<b>Battery management</b>	Automatic control of the battery charge status; the battery complies with air transport regulations. Each battery can last about 4h
<b>Resolution</b>	<136eV
<b>Data transmission</b>	USB
<b>Temp. range environment</b>	-20°C + 50°C
<b>Ambient humidity range</b>	10%-90% relative humidity, non-condensing
<b>Display</b>	5.7", color touch display, retractable
<b>Test time</b>	Customizable, from 3 to 60 seconds
<b>Safety</b>	Light indicator during the analytical phase, safety on the door that interrupts the emission of the rays.
<b>SDD</b>	Accuracy 2-3 ‰
<b>SiPIN</b>	Accuracy 3-4 ‰

### Calibration:

ingots, yellow gold, rose gold, white gold, platinum, silver, powders

### Analyzable elements:

Au, Ag, Pd, Pt, Rh, Ru, Ir, W, Fe, Cr, Co, Ni, Cu, Ti, Zn, Se, Cd, In, Pb

Very fast analyzer in analysis and easy to use software.

High performance thanks to high spectral resolution

Industrial-tactile display, automatic brightness adjustment.

Real-time battery management.

Practical energy saving: it goes into stand-by when not in use and restarts when you pick it up, thanks to the gravity sensor.

Check that humidity and temperature parameters are within environmental specifications.

The work reports are customizable: you can add logo, address, description, origin and batch.

The instrument has proximity control which guarantees its safety.

The tool can be configured and verified via the web



### GOLD S

Value in carats, analysis in % Pt:

Value in percentage or ppm Ag: Value in percentage or ppm.

Percentage content for other alloys

Wide calibration range in carats for gold, platinum and silver fineness

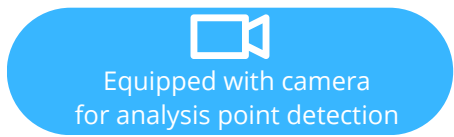

### GOLD

Fast, accurate and non-destructive precious metal analysis

Precious metal fineness identification

Analysis of 19 precious metal-like elements for better estimation. Designed for pawn shops, jewelry stores, mining industry, gold industry, gold buyers, dentists, goldsmith laboratories, metal counter, Analysis of bars, coins, necklaces, bracelets, rings, powders, straps, belts, bars

Grade of gold in karats, other mixed alloys, Platinum.



## Technical characteristics of portable XRF analyzers

<b>Weight</b>	1.6Kg (with battery)
<b>Dimension</b>	254 x 79 x 280 mm (W x D x H)
<b>Tube</b>	40 to 50KV/200µA, Target Ag (standard), Au-W and Rh(optional)
<b>Detector</b>	Si-PIN/SDD
<b>System</b>	4.3" touch screen. Professional operating system with software. Different types of languages including Italian and English. Automatic brightness depending on the surrounding environment
<b>Characteristics</b>	Via USB you can connect the unit to the Internet, any repairs and settings can be done remotely. Data can exported to either EXCEL or PDF. The user can customize the report with the company logo, test results, spectra, product description, origin, batch number, operator. 32GB memory.
<b>Cooling down</b>	The XRF analyzer comes with an integrated radiator, to dissipate heat, located at the top of the instrument.
<b>Safety</b>	Dual beam technology, with automatic sample verification in front of the analytical window: safety and security. Waterproof, airtight seal also resistant to dust, impact resistant suitcase
<b>Battery management</b>	Real-time automatic control of battery charge status. The battery complies with air transportation regulations, one battery can last up to about 4 hours.
<b>SDD</b>	Accuracy 3‰
<b>SiPIN</b>	Accuracy 5‰

### Calibration:

ingots, yellow gold, rose gold, white gold, platinum, silver, powders

### Analyzable elements:

Au, Ag, Pd, Pt, Rh, Ru, Ir, W, Fe, Cr, Co, Ni, Cu, Ti, Zn, Se, Cd, In, Pb

Very fast analyzer in analysis and easy to use software

High performance thanks to high spectral resolution. Industrial-tactile display, automatic brightness adjustment.

Real-time battery management.

Practical energy saving: it goes to rest when not in use and restarts when you pick it up thanks to the gravity sensor.

Check that humidity and temperature parameters are within environmental specifications

The work reports are customizable: you can add logo, address, description, origin and batch.

The instrument always checks before each analysis that the sample is in front of the analytical window

The tool can be configured and verified via the web.



## ALLOY

Analysis of iron-based alloys.

Analysis of nickel base alloys.

Analysis of cobalt-based alloys.

Analysis of titanium-based alloys.

Analysis of copper-based alloys.

Analysis of large aluminum alloys, from the 1000 series to the 8000 series, without identifying the specific alloy.

## ALLOY S

Analysis of all alloys as in the Alloy model.

Analysis of aluminum alloys with identification of light metals such as aluminium, magnesium, silica, phosphorus and sulphur.



## Technical characteristics of portable XRF analyzers

<b>Weight</b>	1.6Kg (with battery)
<b>Dimension</b>	254 x 79 x 280 mm (W x D x H)
<b>Tube</b>	40 to 50KV/200µA, Target Ag (standard), Au-W and Rh (optional)
<b>Detector</b>	Si-PIN/SDD
<b>System</b>	4.3" touch screen. Professional operating system with software. Several languages including Italian and English. Automatic brightness depending on the surrounding environment.
<b>Characteristics</b>	The unit can be connected to the Internet via USB, any interventions and settings can be done remotely. Data can be exported to either EXCEL or PDF. The user can customize the report with the company logo, test results, spectra, product description, origin, batch number, operator. 32GB memory.
<b>Cooling down</b>	The XRF analyzer comes with an integrated radiator, for better heat dissipation, located at the top of the instrument.
<b>Safety</b>	Dual beam technology with automatic sample verification in front of the analytical window. Waterproof, hermetic seal also resistant to dust. Impact-resistant suitcase for safe use on the move.
<b>Battery</b>	Real-time automatic control of battery charge status. The battery complies with air transportation regulations, one battery can last up to about 4 hours.

### Alloy elements:

Ti, V, Cr, Mn, Fe, Co, Ni, Cu, Zn, W, Zr, Nb, Mo, Ag, Cd, Sn, Sb, Pb, Bi, Au

### Alloy S elements:

Mg, Al, Si, P, S, Ti, V, Cr, Mn, Fe, Co, Ni, Cu, Zn, W, Zr, Nb, Mo, Ag, Cd, Sn, Sb, Pb, Bi, Au

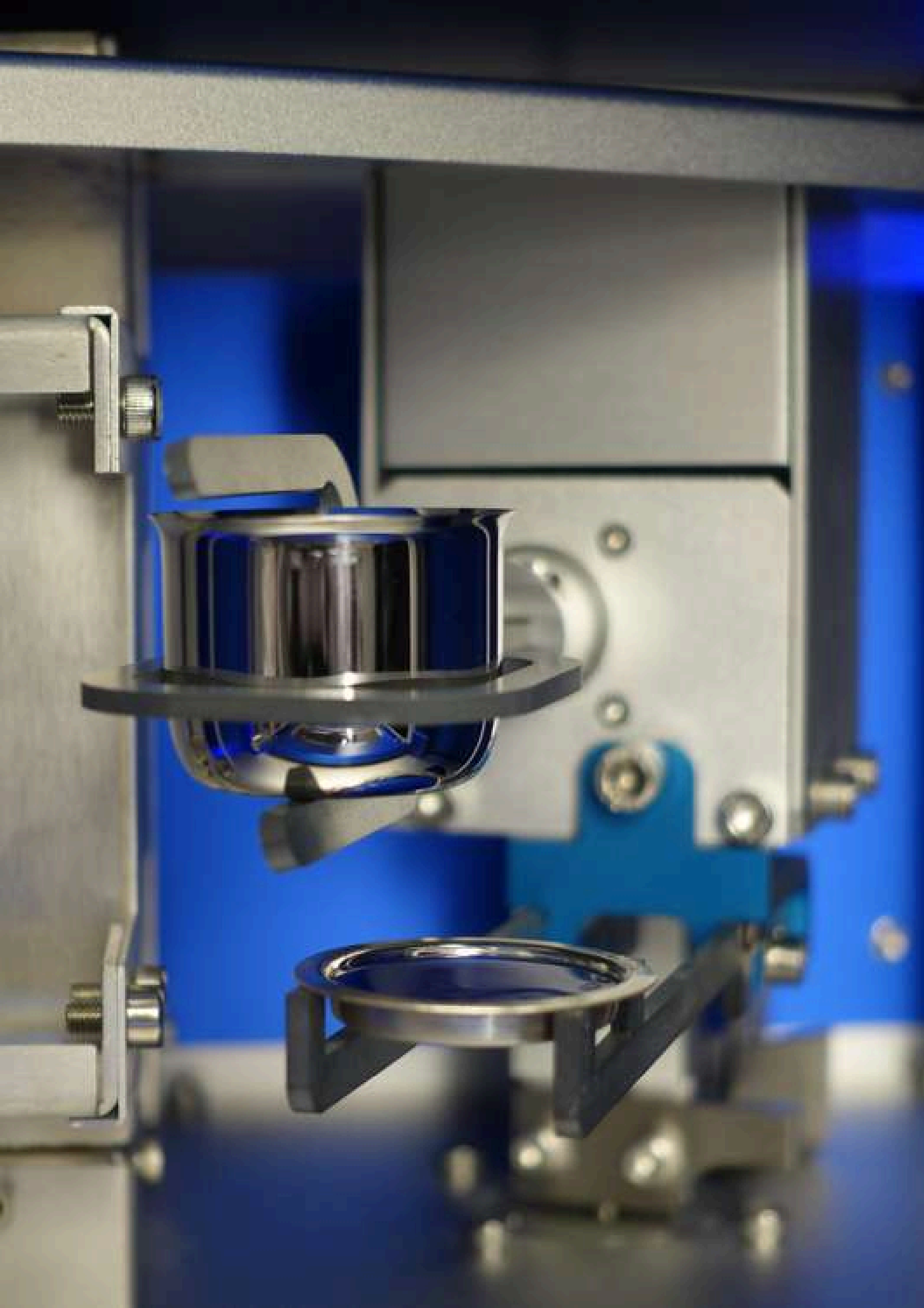



# ELECTRIC FUSION MACHINES



## Why buy our fusion machines

**High productivity** - Our beading machines allow you to prepare glass discs (beads) for XRF or prepare peroxide or pyrosulfate melts.

With the X-300 it is also possible to carry out solid oxidations. This unit allows you to run up to 3 samples at a time, reaching a throughput of 15 samples per hour. Since the saucers are located in the oven with the crucibles, you also have optimal conditions for pouring.

With the X-600, with 6 samples at a time, a productivity of 24 samples per hour is achieved

**Expandable** - You can pre-configure the X-300 fusion machine to suit your needs. **It also allows the user to expand the unit from one location to two or three locations.**

**Safety** - No gas is used in the cooling phase, therefore no risk.

**Precision** - Our beading machines feature precise temperature control with direct measurement on the sample thanks to the Dynamic Temperature Profile (DTP). Analysts will benefit from temperature homogenization for all sample positions in the oven, offering the best reproducibility on the market.

**Reliability** - Made with the most demanding laboratories in mind.

Their design incorporates rugged heating elements, ceramic mounts, industrial motors and electronics that can withstand continuous use.

**Simplicity** - The elegant and intuitive LCD touch-screen interface, with icons and menus, makes operation easy and efficient. All programs can be saved, renamed, deleted or copied. The software is pre-installed in multiple languages.

**They are entirely automated and are supplied with different casting programs already prepared for the needs of the end customer: your methods will be developed before and after purchasing the instrument, free of charge.**

**Solutions Module** - Optional Variable Speed Solution Mixer allows the X-300 and X-600 to produce solutions for ICP/AA analysis in up to three to six beakers simultaneously.

**Connectivity** - You can remotely connect to the system to monitor or interact with the interface via smartphone, computer or tablet. When connected, the user can activate an option that allows a Katanax technician to access the system for diagnostic and troubleshooting purposes.

**Data Logging** - Allows you to track samples using the on-screen keyboard or a barcode reader. Data can be retrieved manually with a USB stick or remotely via FTP over Ethernet and can be integrated into an automated LIMS system.

## X-100 fusion machine

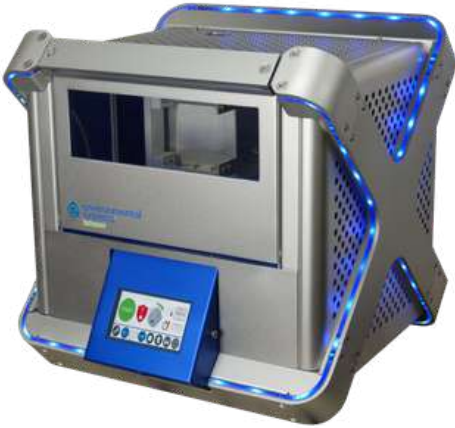

<b>Voltage</b>	115 - 230 VAC
<b>Max power</b>	1500 W
<b>Industrial socket</b>	16 A
<b>Temp max</b>	1200°C
<b>Frequency</b>	50-60Hz
<b>Weight</b>	22 kg
<b>Height</b>	42 cm [16.5"]
<b>Depth</b>	42 cm [16.5"]
<b>Width</b>	42 cm [16.5"]

The Katanax® X-100 fluxer is a key part of our new offering in next-generation electric fusion, providing exceptional flexibility for outstanding ease of use and unparalleled results.

This single position fluxer is perfect for the needs of today's entry level modern laboratories.

The Katanax® X-100 equipment showcases state-of-the-art technology, establishing itself as a premier high-end solution. Its throughput, while optimized for efficiency, aligns with the requirements of lower throughput labs.

Thanks to a clever electrical and physical design, this compact unit will fit on any counter size and works on both 115 or 230V single phase supply line. The X-100 is equipped with revolutionary heating elements that are resistant to flux and chemical attacks. Heating elements can be changed individually, and will not become brittle. Not only does it feature amazing heating elements, but the crucible and mold holders are also made of the same material, allowing a very high life expectation, they can be cleaned and re-used.

### Characteristics

Seamlessly transform your lab with proven fusion technology  
The most compact version of our X series fluxers for entry level laboratories

- 1 Electric fusion fluxer for sample preparation versatility for XRF (beads) or ICP Analysis (solution)
- 2 Identical reliability and accuracy to our larger X series fluxers
- 3 Self-contained effortless operation with fully automated heating and sample processing

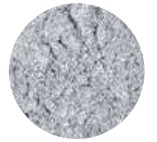

## Advantages X-100

### Seamless Fusion for First-Time Users :

- Plug-and-play furnace without pre-conditioning or calibration requirements
- No site updates required with single-phase power (115v-230v)
- Ready for fusion immediately following installation with built-in methods

### Reliability and Dependable Accuracy :

- Reproducible X series Fluxer functionality with single-sample capacity
- Entirely automated process with customizable methods
- Optimal pouring conditions—both mold and crucible are present in the furnace

### Designed for Laboratory Safety Users :

- Self-contained preparation method, cold-to-cold
- Compact cubic size of only 42 cm with no external power supplies

### Versatility for any Workflow

- Makes glass disks (fusion beads) for XRF analysis
- Capable of both solution and peroxide fusion (for hard to oxidize materials or precious metal), for ICP analysis



### FLUX

Superior quality, pre-cast microspheres Available with or without integrated non-lubricating agents (LiBr or Lil).

## X-300 fusion machine

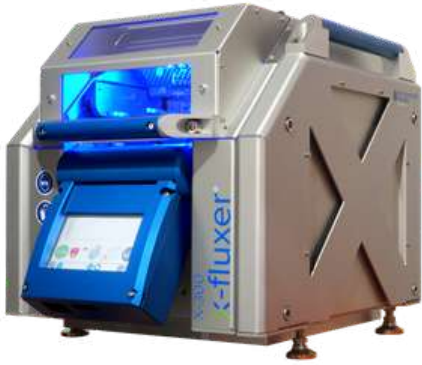

<b>Voltage</b>	115-230 VAC single phase
<b>Max power</b>	3000 Watt
<b>Industrial socket</b>	16 A
<b>Temp max</b>	1200°C
<b>Frequency</b>	50-60Hz
<b>Weight</b>	45kg (99 lbs)
<b>Height</b>	51cm / 20in
<b>Depth</b>	63cm / 25in
<b>Width</b>	48cm / 19in

### Characteristics

- ① High performance oven
  - Flux waterproof heating elements
  - No exposed metal in the oven
  - It heats up quickly
- ② The door is self-locking, protects the user during the casting process.
- ③ Silent during standby, heating, melting and cooling phases.
- ④ Supports for crucibles and ceramic saucers, easy to clean and inert to flux. The system is user configurable for 30, 32, 35 or 40 mm saucers.
- ⑤ The extraction channels allow direct ventilation of the halogens in every position of the crucible.
- ⑥ The control panel is adjustable and has a USB connection for firmware updates.

### Flexibility/expandability

The X-300 can be purchased initially with one position and subsequently it will be possible to implement it with up to 3 positions based on work needs.



## Advantages X-300

### Heating elements:

- Impervious to flux and other additives
- Thanks to its robustness the unit can be moved without damaging the elements
- Automatic power calibration maintains a consistent temperature from location to location
- The resistor is simple to replace; does not require conditioning procedures
- Elements can be replaced individually

### Oven:

- Compensation of individual elements. Allows uninterrupted operation even if an element fails
- The Dynamic Temperature Profile (DTP) helps maintain a uniform temperature
- The oven heats up quickly
- The use of ceramic eliminates metallic contamination
- **Configurable with single, double or triple position**

### Other functions:

- Silent during standby, heating, melting and cooling
- No external power supplies are needed: no power box or cooling fluids
- Industrial PLC interface: does not depend on Windows updates
- Single-phase power supply: does not require three-phase
- Ambient status light: red when processing, blue when complete

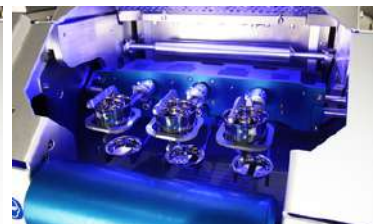
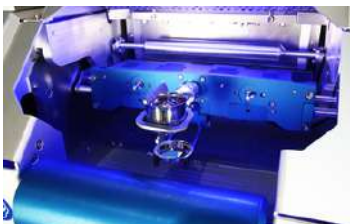

### FLUX

Superior quality, pre-cast microspheres Available with or without integrated non-lubricating agents (LiBr or LiI).

## X-600 fusion machine



<b>Voltage</b>	115-230 VAC single phase
<b>Industrial socket</b>	16A
<b>Max Power</b>	4000 Watt
<b>Temp Max</b>	1200°C
<b>Frequency</b>	50-60Hz
<b>Weight</b>	95kg (210 lbs)
<b>Height</b>	56cm / 22in
<b>Depth</b>	69cm / 27in
<b>Width</b>	105cm / 41in

### Characteristics

- ①
  - Flux waterproof heating elements
  - No exposed metal in the oven
  - It heats up quickly
- ② The door is self-locking, protects the user during the casting process
- ③ Low noise level during heating, melting and standby.
- ④ Supports for crucibles and ceramic saucers, easy to clean and inert to flux. The system is user configurable for 30, 32, 35 or 40 mm saucers.
- ⑤ The extraction tubes allow direct ventilation of the halogens from every position of the crucible.
- ⑥ The control panel is height-adjustable and has a USB connection for firmware updates.



# Advantages X-600

## Heating elements:

- Impervious to flux and other additives
- Robust and indestructible; the unit can be moved without damaging the elements
- Automatic power calibration maintains a uniform temperature between stations
- The resistor type is simple to replace; no conditioning procedures are necessary.
- Elements can be replaced individually.

## Oven:

- Compensation of individual elements allows uninterrupted operation even if one element fails
- The Dynamic Temperature Profile (DTP) helps maintain a uniform temperature
- Rapid heating
- The use of ceramic eliminates metallic contamination

## Assistance and maintenance:

X-Fluxer units require little maintenance due to their reliability. Servicing these units is made simple with easy access to components and support from our dedicated service team.

## Other characteristics:

- Low noise during heating, melting and standby
- Industrial PLC interface; it is independent of Windows updates
- Single-phase power supply; does not require three-phase
- No external power supplies are required, no cooling fluid and compressed air supply



### FLUX

Superior quality and pre-cast microspheres. Available with or without integrated non-lubricating agents (LiBr or LiI).



# Fluxes

Fluxes are used to drop the sample's fusion temperature, reducing fusion time.

The ratio fluxes/sample is according to the application it could be from 1:4 until 1:10 or more.

The fluxes could be **pure** (99.99%) or **ultrapure** (99.998%) according to the customer needs and in the formula could be already added the wetting agent like LiI or LiBr.

The choice regarding the appropriate flux depending about the matrix itself, here some informations:

CEMENTS/KLINKER	LiT/LiBr	99.5/0.5%
DOLOMITE/LIMESTONE	LiT/LiM/LiBr	66/33.5/0.5%
SILICATES	LiM/LiBr	99.5/0.5%
SAND/CLAY	LiM/LiT/LiBr	66/33.5/0.5%

If you need any suggestion about the right flux to use with your matrix, you can contact us directly by phone or by mail.



KP3000P	LiM/LiBr 99.5/0.5% 1kg (Micro-beads)
KP3000UP	LiM/LiBr 99.5/0.5% 1kg ultra pure (Micro-beads)
KP3001P	LiT/LiBr 99.5/0.5% 1kg (Micro-beads)
KP3001UP	LiT/LiBr 99.5/0.5% 1kg ultra pure (Micro-beads)
KP3002P	LiT/LiM/LiBr 49.75/49.75/0.5% 1kg (Micro-beads)
KP3002UP	LiT/LiM/LiBr 49.75/49.75/0.5% 1kg ultra pure (Micro-beads)
KP3003P	LiT/LiM/LiBr 66.67/32.83/0.5% 1kg (Micro-beads)
KP3003UP	LiT/LiM/LiBr 66.67/32.83/0.5% 1kg ultra pure (Micro-beads)
KP3004P	LiT/LiM/LiBr 34.83/64.67/0.5% 1kg (Micro-beads)
KP3004UP	LiT/LiM/LiBr 34.83/64.67/0.5% 1kg ultra pure (Micro-beads)
KP3005P	LiM/LiBr 98.5/1.5% 1kg (Micro-beads)
KP3005UP	LiM/LiBr 98.5/1.5% 1kg ultra pure (Micro-beads)
KP3006P	LiM 100% 1kg (Micro-beads)
KP3006UP	LiM 100% 1kg ultra pure (Micro-beads)
KP3007P	LiT 100% 1kg (Micro-beads)
KP3007UP	LiT 100% 1kg ultra pure (Micro-beads)
KP3008P	LiT/LiM 50/50% 1kg (Micro beads)
KP3008UP	LiT/LiM 50/50% 1kg ultra pure (Micro beads)
KP3009P	LiT/LiM 66/34% 1kg (Micro beads)
KP3009UP	LiT/LiM 66/34% 1kg ultra pure (Micro-beads)
KP3010P	LiT/LiM 35/65% 1kg (Micro-beads)
KP3010UP	LiT/LiM 35/65% 1kg ultra pure (Micro-beads)
KP3011P	LiT/LiM/LiI 66.67/32.83/0.5% 1kg (Micro-beads)
KP3013P	LiM/LiI 99.5/0.5% 1kg (Micro-beads)
KP3013UP	LiM/LiI 99.5/0.5% 1kg ultra pure (Micro-beads)
KP3014P	LiT/LiM/LiI 49.75/49.75/0.5% 1kg (Micro-beads)
KP3014UP	LiT/LiM/LiI 49.75/49.75/0.5% 1kg ultra pure (Micro-beads)
KP3015P	LiT/LiM/LiI 66.67/32.83/0.5% 1kg (Micro-beads)
KP3015UP	LiT/LiM/LiI 66.67/32.83/0.5% 1kg ultra pure (Micro-beads)
KP3016P	LiT/LiI 99.5/0.5% 1kg (Micro-beads)
KP3016UP	LiT/LiI 99.5/0.5% 1kg ultra pure (Micro-beads)
KP3017P	LiM/LiI 99.9/0.1% 1kg (Micro-beads)
KP3018P	LiT/LiI 99.9/0.1% 1kg (Micro-beads)
KP3026P	LiT/LiM/LiI 34.83/64.67/0.5% 1kg (Micro-beads)

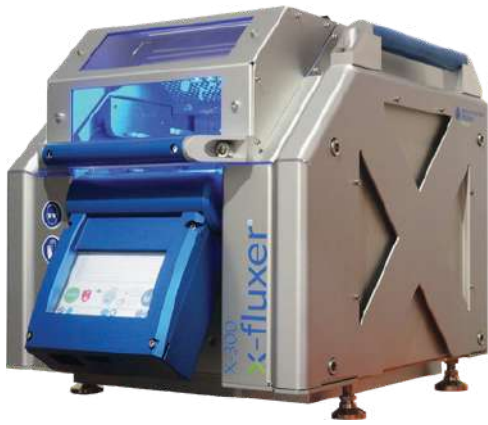

**FREE**



## Method development

If you are looking to purchase a fusion machine and would like to find out if and how your sample can be processed by Katanax fusion, we would be glad to assist you, **this service is always at no additional charge before and after the purchase of the equipment.**

We will be pleased to assist you by phone first to understand exactly what your needs and expectations are, you can send us an email, with your contact details including providing the time you prefer, or by calling directly.

Then you will simply scan the qrcode below, download the form to send to [info@88labware.com](mailto:info@88labware.com), and send us your material samples and we will develop the fusion method for you.

This free service will provide you with the fusion method fully developed by us, keeping in mind, however, that it may not be the most time-efficient method. We believe that from this solution, the customer can then work independently.



**Send form at: [info@88labware.com](mailto:info@88labware.com)**





# PLATINUM CARE



## Platinum: the metal that combines elegance, prestige and functionality. How to take care of it?

Platinum is a precious and rare metal that offers numerous advantages for laboratory applications. Due to its high resistance to corrosion and high temperatures, platinum is the ideal material for crucibles, filters, capsules and other instruments used in chemical analysis. Furthermore, platinum has a remarkable catalytic capacity which facilitates the combustion of organic residues and reduces analysis times.

However, platinum is not indestructible and requires some precautions to maintain its properties and prolong its life. Pure platinum is very ductile and tends to deform when exposed to temperatures above 700°C. To increase its mechanical resistance, platinum alloys can be used with other platinum group metals, such as iridium, gold or rhodium. These alloys also have the advantage of reducing the mass loss of platinum through evaporation.

To prevent platinum from deteriorating, it is important to avoid contact with substances that can react with it and form low-melting compounds. These substances include silicon, phosphorus, boron, sulfur and other metals. These reactions can occur in both oxidation and reduction conditions, but are more dangerous in the latter, because they can release the so-called "platinum poisons", which compromise its quality. For this reason it is recommended to always perform analyzes in an oxidizing atmosphere and to use an oxygen-rich blue flame when heating platinum with a Bunsen burner.

Another source of damage to platinum can be contact with foreign materials, such as silicon carbide heating rods in muffle furnaces or metal fragments on the bottom of the furnace. These materials can diffuse into platinum and alter its composition and structure. To prevent this problem, it is recommended to carefully clean the laboratory surfaces where platinum instruments are placed and to use only ceramic or platinum supports to lift them. Furthermore, you must avoid touching the hot platinum with pliers or tweezers that do not have platinum-coated tips, so as not to contaminate it with corrosive substances.

By following these simple rules you can guarantee a long life for platinum products for laboratory analysis and obtain reliable and precise results. Platinum is an investment that pays for itself over time thanks to its quality and durability.



## How do acids and molten salts affect it?

During wet chemical analyses, it is important to keep in mind that halogen compounds, nitric acid and other highly oxidizing acidic mixtures can cause corrosion of platinum even at room temperature (see table on next page). Additionally, the melting of alkali metal hydroxides and cyanides at elevated temperatures can accentuate corrosive effects. In particular, potassium compounds tend to react more intensely than the corresponding sodium salts with platinum instruments.

To prevent oxidation of the crucible, during soda and soda-potash melts, it is advisable to cover the crucible to create a carbon dioxide atmosphere on the melt.

## How to obtain a correct warm-up

It is important to avoid heating platinum braces for extended periods of time, as this can cause their crystalline structure to swell, become brittle and crack. In addition, platinum appliances to be incinerated should not come into contact with other metals, such as crucible tongs, tweezers, iron triangles, wire mesh, etc. During the cooling process, the ceramic surface on which the appliance rests inside the oven must be clean and completely free of contaminants. When burning several new platinum appliances in the muffle furnace at the same time, it is important to ensure that they are not in contact with each other, especially in the case of crucibles with new lids.

## How can I increase the life of the products?

Some simple precautionary measures to extend the useful life of products are:

- Use heavily used crucibles when the constituents of the sample are not known
- Never place a crucible directly on a silicon carbide heating rod
- Furnace linings must not contain elements harmful to platinum.
- In the presence of organic materials, ensure good oxidation conditions (possibly adding small quantities of ammonium nitrate before heating)
- Touch hot crucibles only with Pt-coated tongs
- Always use Bunsen burners with a blue/colorless flame (avoid yellow flame = reducing)

## How can I clean my tools properly?

Boiling platinum items in a suitable solvent is sufficient.

If adequate cleaning is not achieved, we recommend dissolving with potassium hydrogen sulfate or potassium diphosphate.

Surface-bonded materials can be cleaned with a corundum-based polish. Never use a polish that contains metal carbide.

For any other residue, remove with hydrofluoric acid.

Platinum items should not be cleaned by annealing, as this promotes the unwanted process of diffusion.

## Use of electrodes

Electrolytically precipitated metals are dissolved with pure acids, then the electrodes are cleaned with deionized water and dried in a drying cabinet.

Annealing leads to unwanted softening, which in turn makes the electrodes easier to deform. Furthermore, incompletely dissolved metals could spread permanently.

## PROCESS TEMPERATURES OF OUR ALLOYS

1200 °C	Pt / Ir	997/3
1400 °C	Pt / Au	950/50
1600°C	Pt/Rh	900/100
1750°C	Pt / Ht	900/100

## INFLUENCE OF SUBSTANCES THAT DAMAGE PLATINUM ON THE MELTING TEMPERATURE

Element	Pt		Pd		Au		Ir		Rh		A n	
	°C	°F	°C	°F	°C	°F	°C	°F	°C	°F	°C	°F
B	825	1517	743	1369	1050	1922	961	1762	1131	2068	1046	1915
Si	830	1526	798	1468	370	698	835	1535	1389	2532	1470	2678
P	588	1090	788	1450	935	1715	878	1612	1245	2273	1262	2304
As	597	1107	-	-	665	1229	540	1004	-	-	-	-
Sn	1070	1958	-	-	278	532,4	221	429,8	-	-	-	-
Sb	633	1171	590	1094	360	680	485	905	610	1130	-	-
Pb	290	554	265	509	213	415,4	304	579,2	-	-	-	-
Bi	730	1346	-	-	241	465,8	262	503,6	-	-	-	-
S	1240	2264	623	1153	-	0	742	1368	925	1697	-	-

## PHYSICAL DATA OF PRECIOUS METALS AND PRECIOUS METAL ALLOYS

Material	Melting point, melting range		Density (g/cm3)	Linear expansion coefficient (20-100°C) 10 <sup>-6</sup> (K <sup>-1</sup> ) (68-212°F) 10 <sup>-6</sup> (K <sup>-1</sup> )	Specific electrical resistance (annealing) at 20° C (Ω*mm <sup>2</sup> *m <sup>-1</sup> ) 68° F (Ω*mm <sup>2</sup> *m <sup>-1</sup> )	Temperature coefficient of specific electrical resistance (0-100°C) 10 <sup>-4</sup> (K <sup>-1</sup> ) (32-212°F) 10 <sup>-4</sup> (K <sup>-1</sup> )
	°C	°F				
Pt	1769	3216,2	21,45	9,1	0,107	39,0
Ir	2447	4436,6	22,65	6,8	0,049	43,0
Pd	1554	2829,2	12,02	11,1	0,099	38,0
Rh	1963	3565,4	12,41	8,3	0,043	46,0
Os	3050	5522,0	22,61	6,1	0,096	42,0
Ru	2315	4199,0	12,20	9,1	0,073	46,0
Au	1063	1945,4	19,32	14,1	0,027	40,0
Ag	961	1761,8	10,49	18,7	0,016	41,0
PtRh 10	1840-1870	3344-3398	20,00	10,0	0,200	16,3
PtRh 20	1870-1910	3398-3470	18,10	9,3	0,208	13,4
PtIr 10	1780-1800	3236-3272	21,60	8,6	0,250	12,0
PtIr 20	1830-1855	3326-3371	21,70	7,7	0,310	7,5
PtAu 5	1675-1745	3047-3173	21,32	-	0,180	21,0
PtHt	1770	3218	21,45	-	-	-

Material	Thermal conductivity at 20°C (Wm <sup>-1</sup> K <sup>-1</sup> ) 68°F (Wm <sup>-1</sup> K <sup>-1</sup> )	Yield Point (MPa)		Tensile strength		Elongation (MPa) at break(%)		Vickers hardness		Elasticity module (GPa)
		annealing	hard	annealing	hard	annealing	hard	annealing	hard	
Pt	74	70	290	150	330	40	3,0	42	98	170
Ir	59	93	-	450	-	7	-	210	453	528
Pd	75	65	400	180	480	35	3,0	40	210	121
Rh	88	68	-	800	1925	9	-	130	410	380
Os	87	-	-	-	-	-	-	350	1000	570
Ru	105	38	-	500	-	3	-	240	750	430
Au	312	50	260	180	300	40	3,0	40	90	78
Ag	419	120	320	140	380	37	3,0	35	110	80
PtRh 10	30	180	670	300	680	32	1,5	102	204	255
PtRh 20	-	110	920	380	940	32	2,0	113	273	268
PtIr 10	31	220	630	340	650	32	2,0	105	215	220
PtIr 20	-	380	920	570	940	21	2,0	190	300	230
PtAu 5	-	370	610	460	635	7	1,0	139	194	180

## RESISTANCE OF THE PLATINUM, GOLD AND SILVER GROUP TO CORROSIVE METALS

Corrosive	Condition	(°C)	(°F)	Pd	Pt	Rh	Ir	Ru	Os	Au	Ag
Hydrochloric acid	36%	20	68	1	1	1	1	1	1	1	1
Hydrochloric acid	36%	100	212	2	1	1	1	1	3	1	2
Nitric acid	65%	20	68	4	1	1	1	1	3	1	4
Nitric acid	65%	100	212	4	1	1	1	1	4	1	4
Sulphuric acid	96%	20	68	1	1	1	1	1	1	1	2
Sulphuric acid	96%	100	212	3	1	2	1	1	1	1	4
Sulphuric acid	96%	300	572		2	3			1	3	4
Hydrobromic acid	60%	20	68	4	2	2	1	1	1		3
Hydrobromic acid	60%	100	212	4	4	3	1	1	3	1	4
Hydriodic acid	57%	20	68	4	1	1	1	1	2	1	4
Hydriodic acid	57%	100	212	4	4	1	1	1	3	1	4
Fluorohydric acid	40%	20	68	1	1	1	1	1	1	1	1
Phosphoric acid		100	212	2	2	1	1	1	4	1	1
Acetic acid	99%	100	212	1	1	1	1	1		1	1
Hydrochloric acid/chlorine	20%/saturated	20	68	3	2					4	4
Hydrochloric acid/chlorine	20%/saturated	80	176	4	4	2	2			4	4
Hydrochloric acid/chlorine	20%/saturated	100	212	3	3	2				4	4
Hydrochloric acid/bromine		20	68	4	2		1				4
Hydrochloric acid/bromine		100	212	4	2	1	1			4	4
Aqua regia		20	68	4	4	1	3		4	4	4
Aqua regia		100	212	4	4				4	4	4
Aqua regia		150	302	4	4					4	4
Hydrochloric acid/10% H2O2		20	68	4						4	4
Hydrochloric acid/10% H2O2		100	212	4	2					4	4
Hydrobromic acid/bromine	60%	100	212	2	1	4				3	
Water/bromine		20	68	2	1	1	1	1	1	1	2
Ethanol/Iodine		20	68	3	1	2	1	1		1	4
Sodium hypochloride solution		20	68	4	1	2		4	4	4	1
Sodium hypochloride solution		100	212	3	1	2	2	4	4	4	2
Potassium cyanide solution		20	68	4	3					1	4
Potassium cyanide solution		100	212	2	1					2	4
Copper(II) chloride solution		100	212	2	2					4	
NaOH melt	air access	500	932	2	3	2		4	4	4	2
KOH melt	air access	500	932	3		2		4	4	4	3
NaOH melt	air access	800	1472	3	1	2		4	4	2	4
KOH melt	air access	800	1472	2	3	2		4	4	4	4
KHSO4 melt	air access	440	824	3	4	3	1			4	4
NaCN melt	air access	700	1292	4	3	4	3	3		4	4
KCN melt	air access	700	1292	3	2	3	3	3		3	4
NaCN/KCN melt (2:1)	air access	550	1022	3	2	4	3	3		4	4
Chlorine, gaseous	dry	20	68	4	3	1	1	1	1	4	1
Chlorine, gaseous	moist	20	68	4	3	1	1	1	3	4	2
Bromine liquid	dry	20	68	4	1	1	1	1	4		1
Bromine liquid	moist	20	68	1	1	1	1	1	3	1	1
Iodine solid	dry	20	68	2	2	1	1	1	2	1	
Iodine solid	moist	20	68	1	1	2	1	1	1		4
Fluorine gaseous		20	68								1
Hydrogen sulphide gaseous	moist	20	68	1	1	1	1	1	1	1	

1=no corrosion  
2=marginal corrosion  
3=strong corrosion  
4=destructive corrosion

The values shown in this table are for reference purposes and should not be used for specific applications.

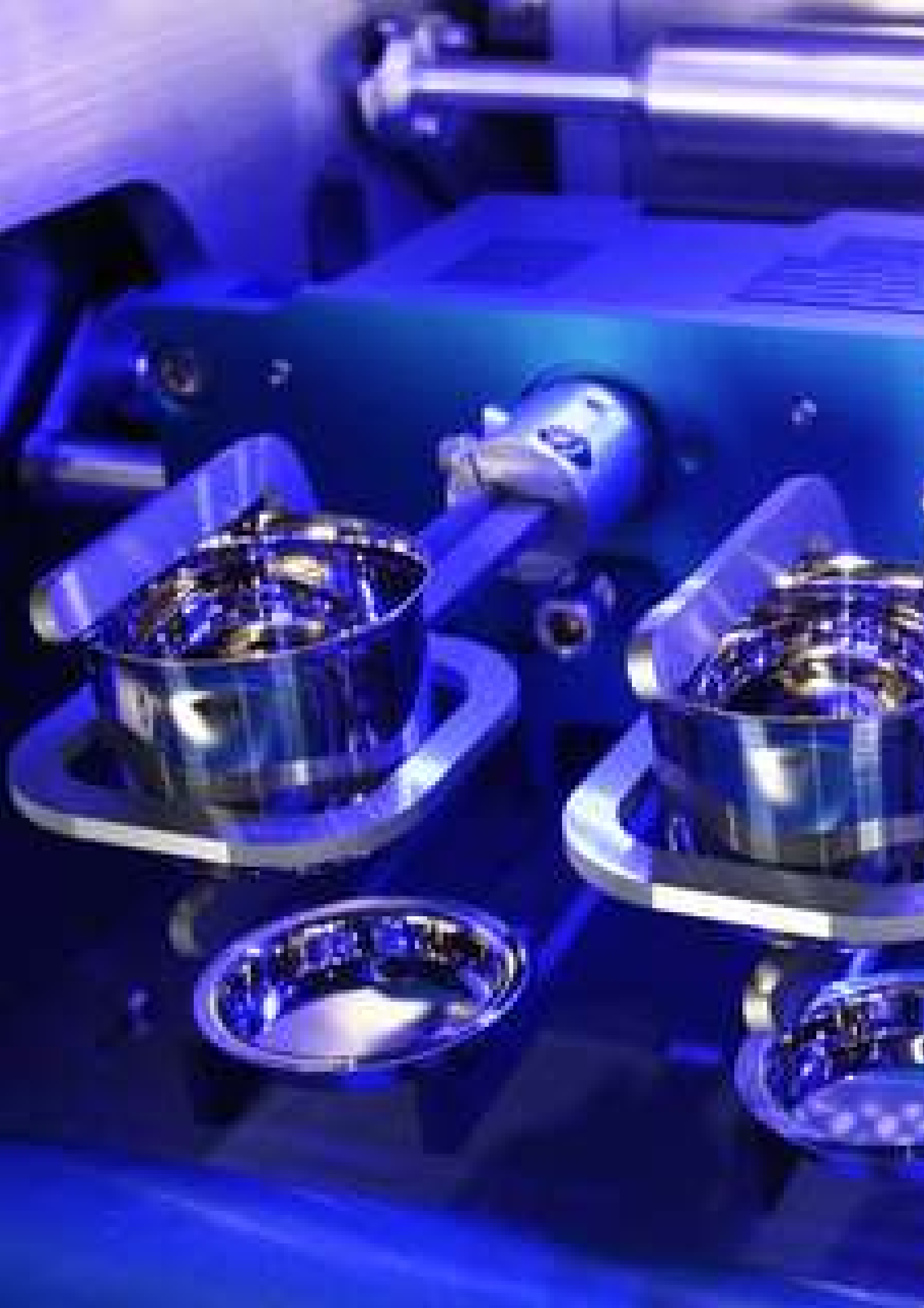





by

**Commercial headquarters - Administrative offices - Factory**

Via Pitagora 11 - 20016 Pero (Mi) Tel. 02  
8853.211 - info@88labware.com  
www.88labware.com

